

INTERFACE

HIU-3 Hub Interface Unit

PRODUCT DESCRIPTION

The HIU-3 is a local, micro-processor controlled sensor interface unit. It is small and light, designed to be mounted on the wheel hub, thus reducing the harnessing on the car. The unit can withstand the high radiated temperatures from the brakes whilst the car is stationary and the vibration from the wheels whilst the car is moving.

The data is transmitted to an appropriate control unit (such as the TAG-400 or MCU-300) over a 2 wire CAN bus communication link.

Electrical

- Supply Voltage 12V to 16V DC (full operation) 7.5V to 11.99V (with some parameter inaccuracies)
- Supply Voltage not to exceed 17V continuous (the unit is protected against transients and reverse polarity)
- Current 150mA typical at 13.8V (including typical transducer loads)

Mechanical

- Hard black anodised aluminium
- Weight approximately 55g

Application

Localised data acquisition

Electro Magnetic Compatibility

- Complies with the essential protection requirements of 2004/108/EC



Connection Definition

Integral, sealed, LEMO series F motorsport connectors

Connector 1	8 way	HES1F308XLDP
Connectors 2, 3, 4, 5	4 way	HEN.FF.304.SLNP

For pin numbers please consult our Technical Consultancy service

Environmental

- Splash resistant to standard motorsport fluids
- Lids and screws sealed with silicone sealant, lid 'O' ring sealed
- Maximum humidity 100%
- Minimum operating temperature 0°C
- Internal Temperature not to exceed 115°C as measured by internal diagnostic sensor. If necessary, cooling for the unit should be applied so the temperature remains within these limits
- Storage Temperature -10°C to +125°C

INTERFACE

HIU-3 Hub Interface Unit

- Vibration 100 to 1000Hz, all axes, 24 hours
- Vibration isolation is recommended

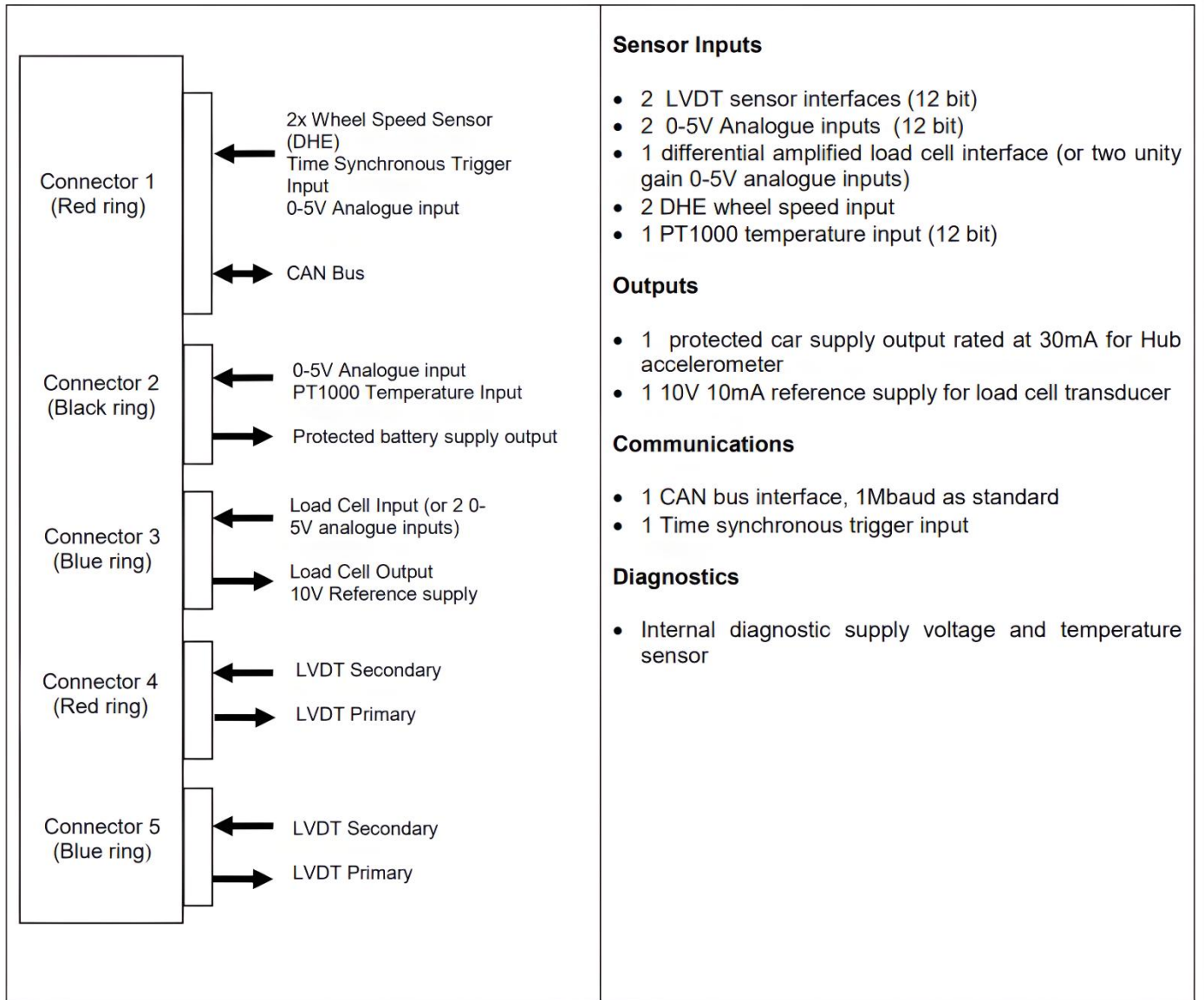

INTERFACE

HIU-3 Hub Interface Unit

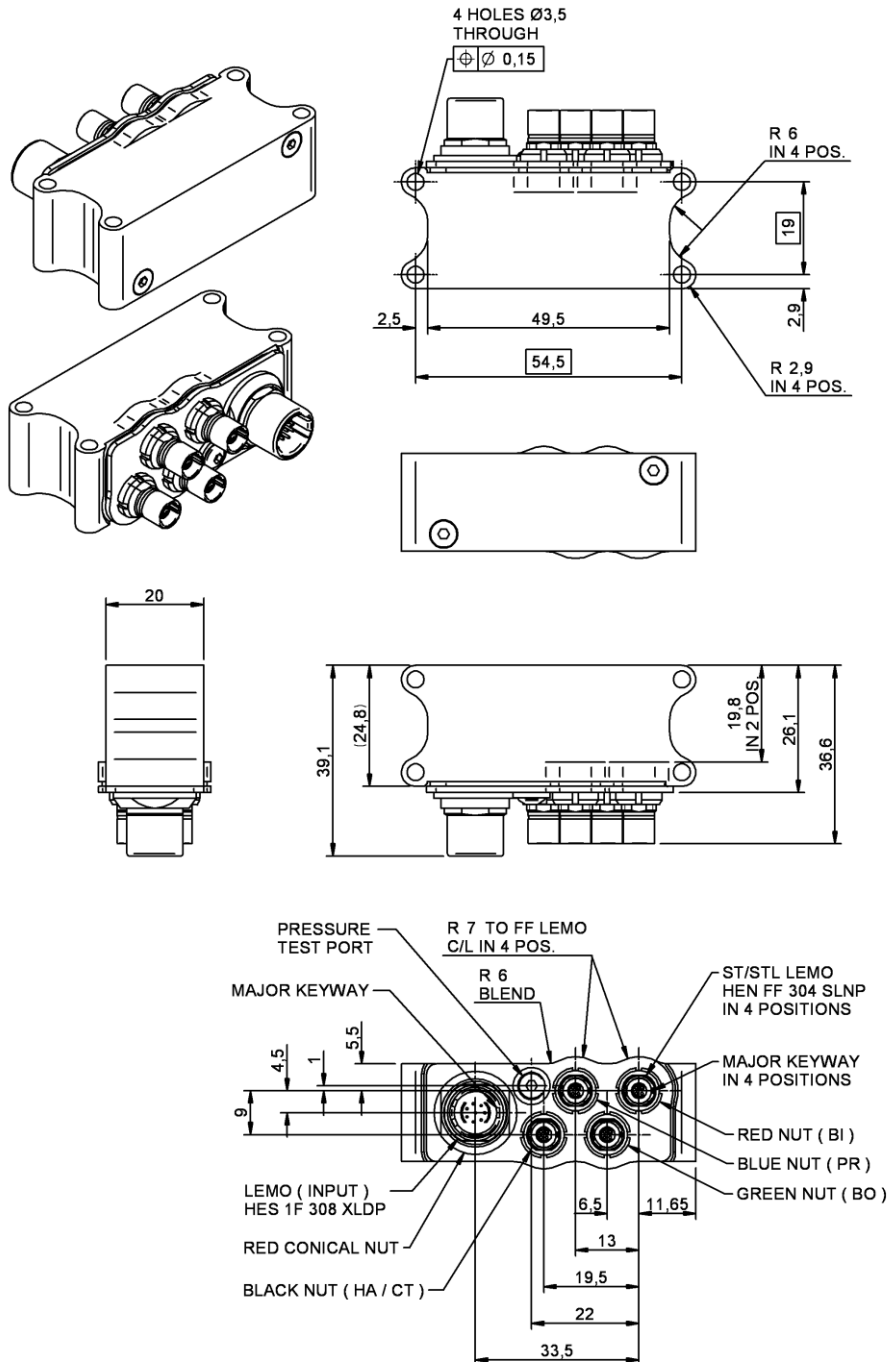

Description	Order Code
HIU-3	0 030 110 008 002