

HIGH-PRESSURE FUEL PUMP DRIVER (HPF-320)

0 030 520 003 018

PRODUCT DESCRIPTION

The HPF-320 is a compact high-pressure fuel pump driver unit for motorsport applications, designed to operate alongside a powertrain control unit. The unit generates a complex current controlled waveform required to activate the pump's solenoid inlet valve directly from a single TTL trigger pulse. The ON trigger pulse from the powertrain control unit commands the total pulse width, whilst the pull-in time, pull-in current, holding current, pull-in hysteresis, and holding hysteresis are defined over CAN.

A single-chip processor is used to set up the waveform and to gather diagnostic information which is transmitted on CAN to the powertrain control unit. An FPGA accepts the external trigger pulses and controls the drive stage based on the waveform configuration from the processor.

ELECTRICAL SPECIFICATION

- Unit Supply Voltage: 8V - 16V
- Unit Pump Supply Voltage: 40V-48V
- 12V Supply Current: <200mA (92uF input capacitance)
- 48V Supply Current 10A Max, (Current limited with 200uF input capacitance)



- Supply reverse and short circuit voltage protection
- Peak Current (Pull-in Current + Hysteresis): Up to 7.5A
- Peak Hold (Hold Current + Hysteresis): Up to 2.8A
- Analogue output for pump current diagnostics:
 - 0-5V, 3.062A/V
- Pump driver output in bridge configuration
 - Assumes a 0.5R, 2.2mH load.
 - Designed for Bosch HDP 6 fuel pump
- Diagnostics provided via CAN:
 - Board Temperature
 - Peak Current
 - Unit Supply Voltages
 - Trigger Count
 - Minimum Pulse Width Violation flag
 - Under-voltage Warning flag (<38.6V)
 - Pump Open Circuit flag

HIGH-PRESSURE FUEL PUMP DRIVER (HPF-320)

0 030 520 003 018

CONNECTION DEFINITION

- Connector 8STA2-1035PN
- Mating Part number: 8STA6-1035SN

Pin	Signal
1	CAN High
2	CAN Low
3	Input - ON trigger
4	Ext Digital Ground Ref
5	Pump Current Output
6	12V Ground
7	12V Supply
8	48V Ground
9	48V Ground
10	48V Supply
11	48V Supply
12	Output - HPFP Return
13	Output - HPFP Send

MECHANICAL

- See attached drawing D100 520 003 018
- CAD Model D016 999 002 580
- Weight <115g.
- Aluminium alloy body, hard anodised and dyed black.

ENVIRONMENTAL

- Vibration 24 hours in 3 axes

Frequency (Hz)	Amplitude (g ² /Hz)
100	0.00797
200	0.171757
300	0.54279
650	0.00965
1000	0.0208

- Shock test: 50g, 1½ sine, 11ms duration, 5 times per axis.
- Sealed and pressure tested to ±30mBar
- Operating temperature -10 to 85°C.
- Resistant to standard motorsport fluids.
- Designed and manufactured to incorporate the 'essential protection requirements' of EMC Directive 2004/108/EC.

DRIVE OUTPUT

CHARACTERISTICS

- Pump start and stop controlled via 1 x external trigger input.
- Waveform configuration controlled with CAN. After initial configuration, the latest waveform will be recalled after each power cycle.
- 15,000 rpm maximum engine speed
- Minimum trigger width 127µs
- Closed-loop current control using PWM
- If open circuit or overcurrent flag is set the output waveform will be terminated and the unit will cease firing until these flags are resolved.

The unit provides a current-controlled waveform as follows:

HIGH-PRESSURE FUEL PUMP DRIVER (HPF-320)

0 030 520 003 018

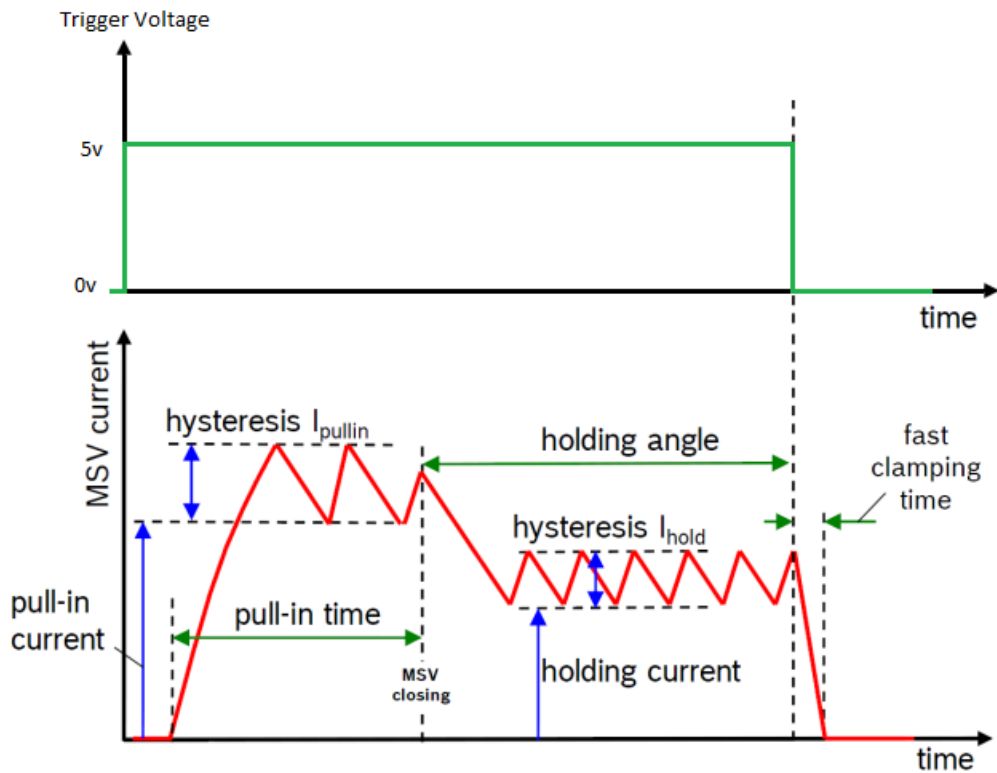

HIGH-PRESSURE FUEL PUMP DRIVER (HPF-320)

0 030 520 003 018

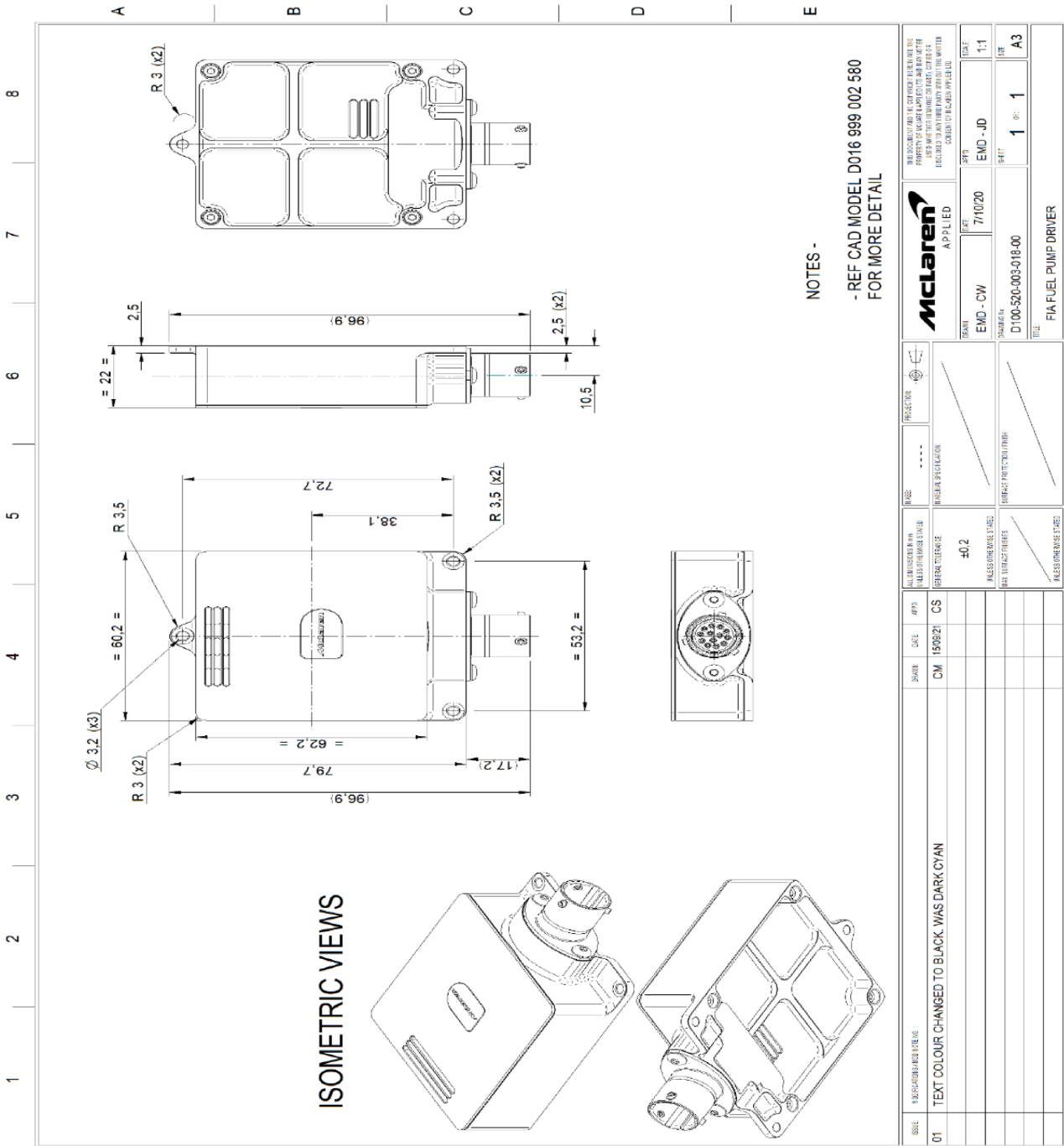

PRODUCT SUMMARY | SCR XXXX | REV YY | LAST UPDATE: DD/MM/YY

HIGH-PRESSURE FUEL PUMP DRIVER (HPF-320)

0 030 520 003 018