

## PCU-510 Display Unit

### PRODUCT DESCRIPTION

The PCU-510 is a lightweight high-resolution driver display module designed for motorsport applications. It is designed to connect to a host ECU via CAN and present the driver with information on a high resolution 12.3" backlit IPS LCD true colour display and LED lamps. The display is suitable for use in direct sunlight and at night. The configuration PC software tool is supplied with the unit. There are 100 pages available that are selectable by a CAN message and each page layout is fully customisable. Mounting points are compatible with the previous PCU-500N driver display module.

### APPLICATION

- Typically remotely mounted on the dashboard

### KEY FEATURES

- Data Display and warning lamps
- 1920 x 720 pixel resolution
- Brightness 600cd/m<sup>2</sup>
- Brightness adjustable via CAN message for low-light conditions.
- 60Hz refresh rate
- Contrast ratio 1200:1
- Live video display from composite video input may be displayed at the same time as other data
- Fifteen RGB high intensity LEDs for a range of user-configurable colours
- Two sets of 3 side high intensity RGB LEDs with current monitoring
- Sixteen gauge types for displaying data, include bar tacho, rev lights and variable text
- Alarm pages or user-configurable text warnings can be triggered by CAN messages



### COMMUNICATIONS

- One Wired Ethernet interface (10/100Mbps)
- One CAN interface configurable as CAN-FD (4Mbps maximum or CAN 2.0 (1Mbps) with no internal termination

### INPUTS

- One reset input (active low with internal pull-up; can be left unconnected if not required)
- One Composite Video Input allows the connection of a rear-view camera
- ELECTRICAL Supply voltage 7.5V to 16V DC
- Supply current operating (All LED indicators and display backlight on maximum brightness) 1.2A@12V
- Transient voltage and reverse-polarity protection

### MECHANICAL

- Aluminium Case (hard black anodised)
- Weight 1.45kg

### CONNECTION DEFINITION

| Pin | Description          |
|-----|----------------------|
| 1   | Unit Supply Positive |
| 2   | Unit Supply Ground   |
| 3   | CAN +                |
| 4   | CAN -                |
| 5   | Ethernet Receive +   |
| 6   | Ethernet Receive -   |

### ENVIRONMENTAL AND COOLING

- Splash resistant to standard motorsport fluids
- Lid has a rubber seal, case fixings are sealed with silicone sealant
- Maximum humidity 95% non-condensing

# PCU-510 Display Unit

## BASE UNIT

| Order Code        | Description          |
|-------------------|----------------------|
| O 030 020 017 000 | PCU-510 Display Unit |

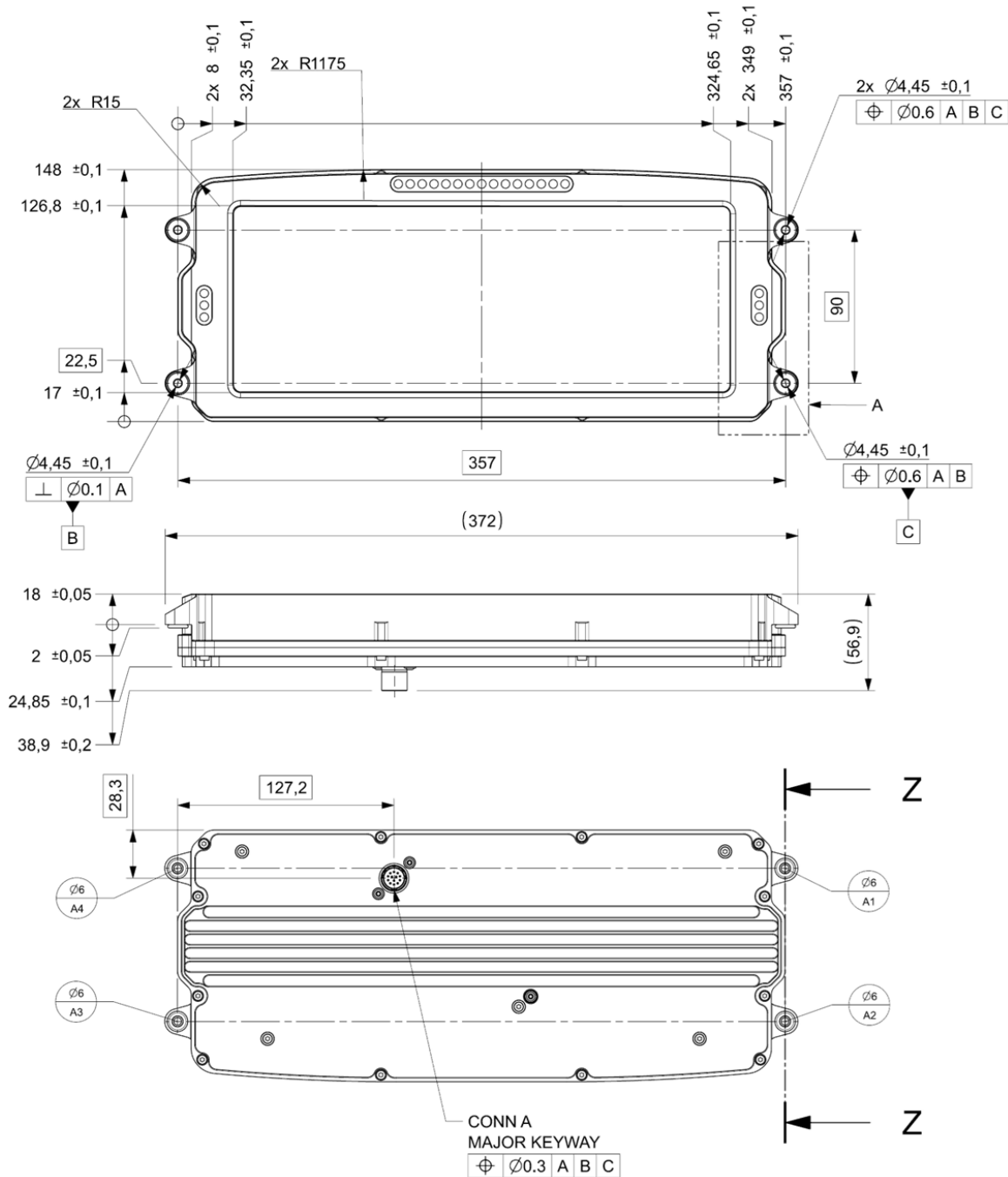

# PCU-510 Display Unit

