

## EIU-510

### PRODUCT DESCRIPTION

The EIU-510 is a companion unit to the TAG-510 which is used to interface to a hybrid, turbo-charged powertrain with up to 8 cylinders.

The unit includes eight transistorised ignition drives and twelve port or GDI injection drives as well as two high pressure fuel pump drives.

### APPLICATION

- Provides power drive stages and monitoring for race car engines
- Up to 8-cylinder direct injection turbocharged engines
- KEY FEATURES
- Data exchange between the EIU-510 and the host ECU is via CAN FD and CAN 2.0 for data logging and configuration.

### DIAGNOSTICS

- Current diagnostics and drive stage fault status flags are provided for all drive stage outputs
- Voltage diagnostics for unit, ignition and injection supplies.
- All voltage and current diagnostics have a 12-bit resolution

### SECURITY

- An MD5 mechanism to provide a secure password protected software locking mechanism and produce unique checksums for the software running on the unit.

### COMMUNICATIONS

- Three CAN FD and CAN 2.0 compatible interfaces with software configurable termination
- One LIN compatible interface



### RoHS COMPLIANCE

- RoHS Compliant

### CONNECTION DEFINITION

- Integral, sealed, Deutsch AS motorsport connectors
- Connector A (16-way), B (66-way), C (21-way) and D (32-way)

### INPUTS

- Twelve configurable active-low injection open drain trigger inputs or active-high using TTL signals
- Eight active-low ignition trigger inputs (Driven using open-drain drivers)
- Two configurable active-low high-pressure fuel pump trigger inputs or active-high using TTL signals
- Four K-type thermocouple inputs
- Two wide-band lambda interfaces for Bosch LSU4.9 and NGK sensors
- One ignition switch input
- Force Boot switch input

## EIU-510

### OUTPUTS

- Twelve injector drivers in bridge configuration providing multi-stage current waveform control. Peak Current 25A Max, Hold Current 10A Max
- Eight transistorised ignition drivers. Peak Primary Current 40A, Primary fly-back voltage 500V Max
- Two high-pressure fuel pump drivers
- Two 5A low-side drive stages – Lambda heaters
- Four 8.5A H-Bridge drive stages – Electronic Throttle Bodies / Waste Gates
- Two diagnostic oscilloscope outputs that are user configurable for viewing injector, ignition or fuel pump drivers

### ELECTRICAL

- Power supply inputs must be provided from an external system power regulator
- Unit Supply input (7.5 to 18V) for internal circuitry
- Dual-rail injection supply inputs (14V nominal and 60V or 80V nominal)
- Ignition supply input (48V nominal)
- Internal tri-axis accelerometer

### MECHANICAL

- Rectangular Cuboid shape
- Aluminium Case (hard black anodised)
- Weight 1400g
- Dimensions 215 x 150 x 60mm

### ENVIRONMENTAL AND COOLING

- IP65 rated
- Splash resistant to standard motorsport fluids
- Lids sealed with O-rings
- Maximum humidity 100%
- Minimum operating temperature 0°C
- Internal temperature not to exceed 70°C as measured by internal diagnostic sensors
- Storage temperature -25°C to +85°C
- Vibration 100 to 1000Hz, all axes, 24 hours
- Vibration isolation is recommended

### ELECTRO MAGNETIC COMPATIBILITY

- Complies with the essential protection requirements of 2014/30/EU

### SERVICE

- Recommended service interval 12 months

# EIU-510

## TAG-510 AND EIU-510 SYSTEM OVERVIEW

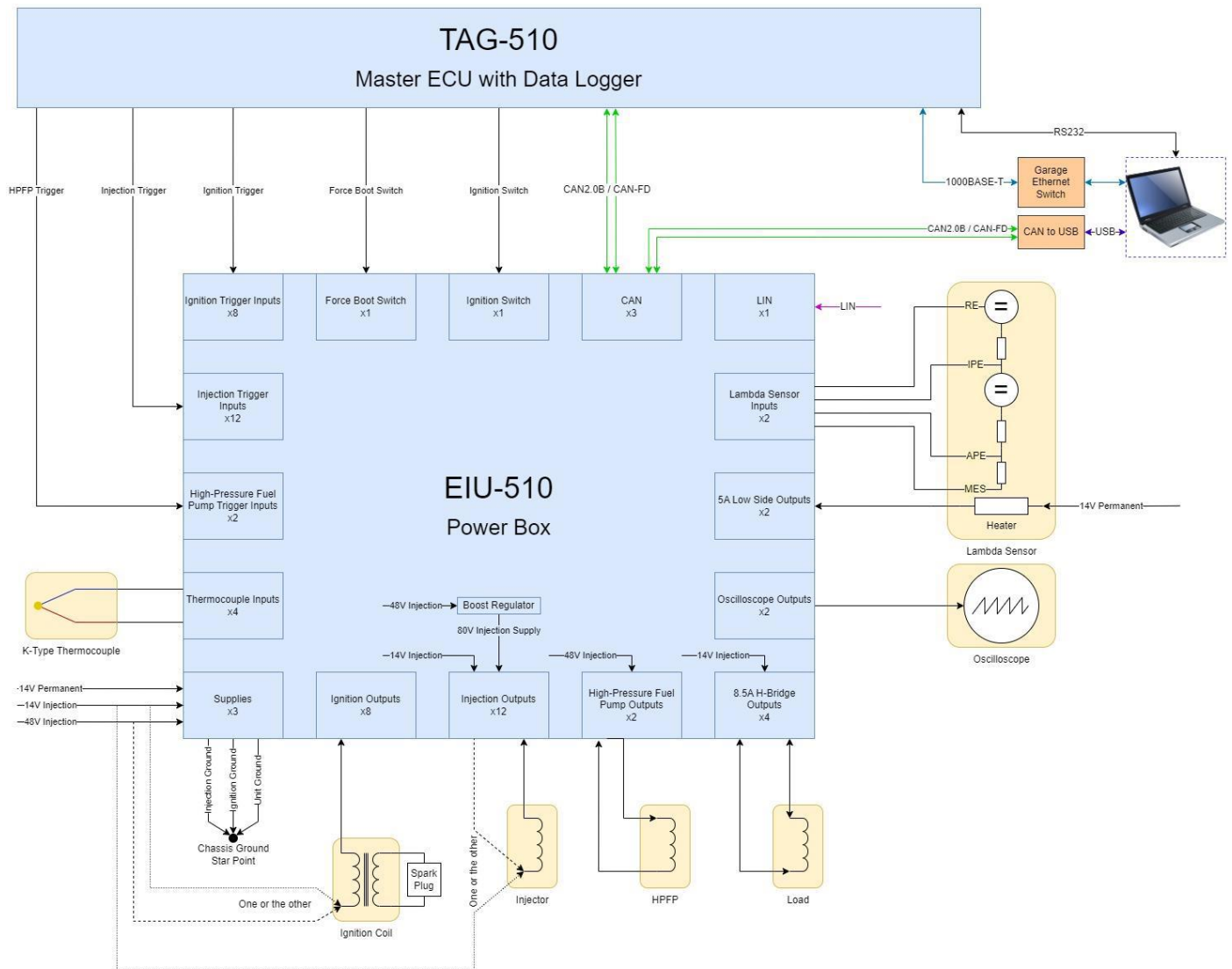

# EIU-510

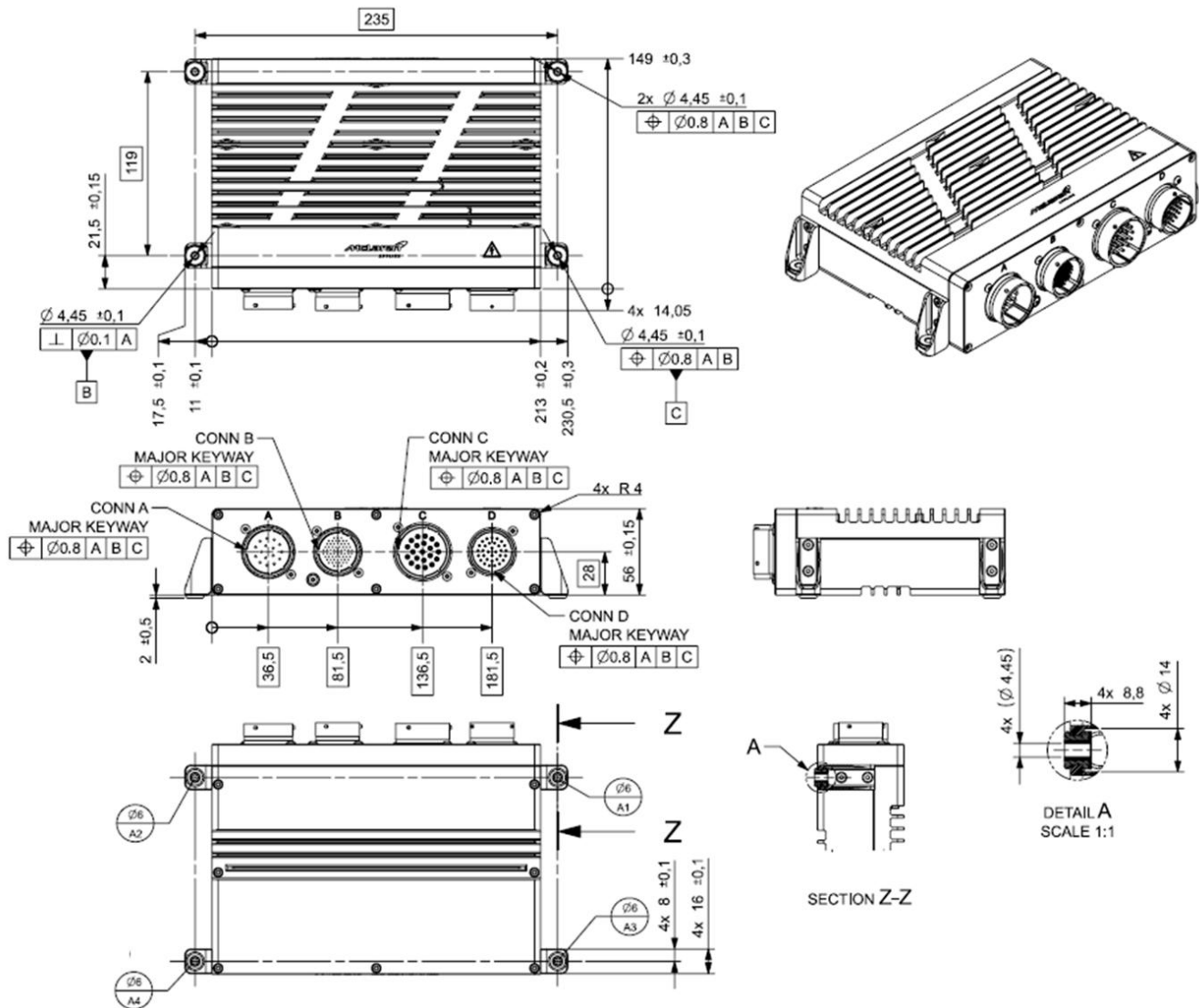

CONN	UNIT CONN PART No.	MATING HALF CONN PART No.
A	DEUTSCH AS2 20-16PN	DEUTSCH AS6 20-16SN
B	DEUTSCH AS2 18-35PN	DEUTSCH AS6 18-35SN
C	DEUTSCH AS2 22-21PN	DEUTSCH AS6 22-21SN
D	DEUTSCH AS2 18-32PN	DEUTSCH AS6 18-32SN